

Plug-N-Play Audio Amplifier Evaluation Platform

User's Guide

IMPORTANT NOTICE

Texas Instruments (TI) reserves the right to make changes to its products or to discontinue any semiconductor product or service without notice, and advises its customers to obtain the latest version of relevant information to verify, before placing orders, that the information being relied on is current.

TI warrants performance of its semiconductor products and related software to the specifications applicable at the time of sale in accordance with TI's standard warranty. Testing and other quality control techniques are utilized to the extent TI deems necessary to support this warranty. Specific testing of all parameters of each device is not necessarily performed, except those mandated by government requirements.

Certain applications using semiconductor products may involve potential risks of death, personal injury, or severe property or environmental damage ("Critical Applications").

TI SEMICONDUCTOR PRODUCTS ARE NOT DESIGNED, INTENDED, AUTHORIZED, OR WARRANTED TO BE SUITABLE FOR USE IN LIFE-SUPPORT APPLICATIONS, DEVICES OR SYSTEMS OR OTHER CRITICAL APPLICATIONS.

Inclusion of TI products in such applications is understood to be fully at the risk of the customer. Use of TI products in such applications requires the written approval of an appropriate TI officer. Questions concerning potential risk applications should be directed to TI through a local SC sales office.

In order to minimize risks associated with the customer's applications, adequate design and operating safeguards should be provided by the customer to minimize inherent or procedural hazards.

TI assumes no liability for applications assistance, customer product design, software performance, or infringement of patents or services described herein. Nor does TI warrant or represent that any license, either express or implied, is granted under any patent right, copyright, mask work right, or other intellectual property right of TI covering or relating to any combination, machine, or process in which such semiconductor products or services might be or are used.

Preface

Related Documentation From Texas Instruments

The TI Plug-N-Play Audio Amplifier Evaluation Platform is designed for use with TI audio power amplifier evaluation modules (EVM). Each audio amplifier EVM uses a TI audio amplifier integrated circuit and is shipped with a user's guide for the module and a data sheet for the IC. For information on additional TI audio ICs or audio EVMs:

- ***Amplifiers, Comparators, and Special Functions Data Book*** (TI literature number SLYD011) This data book contains the data sheets for the TI audio amplifier integrated circuits that are used in the TI Audio Power Amplifier Evaluation Modules
- Individual data sheets for TI audio amplifier integrated circuits
- User's guides for TI audio power amplifier evaluation modules

FCC Warning

This equipment is intended for use in a laboratory test environment only. It generates, uses, and can radiate radio frequency energy and has not been tested for compliance with the limits of computing devices pursuant to subpart J of part 15 of FCC rules, which are designed to provide reasonable protection against radio frequency interference. Operation of this equipment in other environments may cause interference with radio communications, in which case the user at his own expense will be required to take whatever measures may be required to correct this interference.

Trademarks

TI is a trademark of Texas Instruments Incorporated.

If You Need Assistance. . .

If you want to. . .	Do this. . .
Request more information about Texas Instruments products	Call the PIC [†] hotline: (972) 644-5580 Or send a fax to the PIC: (972) 480-7800 Or write to: Texas Instruments Incorporated Product Information Center, MS 3123 P.O. Box 660246 Dallas, Texas 75266
Order Texas Instruments documentation	Call the PIC [†] hotline: (972) 644-5580
Ask questions about product operation or report suspected problems	Call the PIC [†] hotline: (972) 644-5580
Report mistakes in this document or any other TI documentation	Send a fax to MSP Marketing Documentation Correction: (972) 480-3160 Or send your comments to: Texas Instruments Incorporated MSP Marketing Documentation, MS 8710 P.O. Box 660199 Dallas, Texas 75266-0199

[†] Texas Instruments Product Information Center

Contents

1	Introduction	1-1
1.1	Feature Highlights	1-3
1.2	Description	1-4
2	Quick Start	2-1
2.1	Precautions	2-2
2.2	Quick Start List	2-3
3	Details	3-1
3.1	Precautions	3-2
3.2	Configuration	3-3
3.2.1	TI Audio EVMs	3-3
3.2.2	Installing and Removing EVM Boards	3-3
3.2.3	Signal Routing	3-4
3.2.4	Muting and Mode	3-5
3.3	Power	3-7
3.3.1	Platform Power Distribution	3-7
3.3.2	Platform Power Protection	3-7
3.3.3	Platform Power Inputs	3-8
3.4	Inputs and Outputs	3-11
3.4.1	Inputs	3-11
3.4.2	Outputs	3-12
3.5	Troubleshooting	3-13
3.6	Parts List	3-14
3.7	Platform EVM Socket Pinouts	3-15

Figures

1-1	The TI Plug-N-Play Audio Amplifier Evaluation Platform	1-4
1-2	Functional Block Diagram	1-5
2-1	Quick Start Map	2-2
3-1	The Platform	3-2
3-2	Signal Routing Switches	3-4
3-3	Mute/Mode Control	3-5
3-4	Platform Power Distribution	3-7
3-5	Platform Audio Input Jacks	3-11
3-6	Platform Audio Output Jacks and Connectors	3-12
3-7	Signal Conditioning Socket U1 Pinout	3-15
3-8	Power Amplifier Socket U2 Pinout	3-15
3-9	Power Amplifier Socket U3/U4 Pinout	3-16
3-10	Headphone Amplifier Socket U5 Pinout	3-16
3-11	Power Supply/Regulator Socket U6 Pinout	3-16

Tables

3-1	Mute/Mode/Polarity Jumper Select Table	3-6
3-2	Plug-N-Play Audio Amplifier Evaluation Platform Parts List	3-14

Introduction

This chapter provides an overview of the Texas Instruments (TI™) Plug-N-Play Audio Amplifier Evaluation Platform (SLOP097). It includes a list of features and a brief description of the platform illustrated with both a pictorial and a functional block diagram.

Topic	Page
1.1 Feature Highlights	1-3
1.2 Description	1-4



1.1 Feature Highlights

The TI Plug-N-Play Audio Amplifier Evaluation Platform includes the following features:

- Quick and Easy Configuration
 - TI evaluation modules simply plug into the platform
 - Evaluation modules are keyed and cannot be installed incorrectly
 - Install only as many modules as needed
 - On-board jumpers select power and control options
 - On-board switches route signals
 - Add or change modules at any time
- Flexible Power
 - On-board 9-V battery
 - External 5-V – 15-V DC V_{CC} supply input through screw-terminal connectors
 - External 5-V – 15-V AC/DC supply input through standard coaxial power connector
 - On-board bridge rectifier and filter for AC input-power conversion and conditioning
 - Socket for on-board 5 V/3.3 V V_{DD} voltage regulator EVM
 - External regulated V_{DD} input through screw terminals
 - On-board overvoltage and reverse polarity power protection
- Quick and Easy Audio Input and Output Connections
 - Left and right RCA phono jack inputs
 - Miniature stereo phone jack input
 - Left and right RCA phono jack outputs
 - Left and right compression speaker terminal outputs
 - Miniature stereo headphone jack output

1.2 Description

The TI Plug-N-Play Audio Amplifier Evaluation Platform is a convenient vehicle for evaluating, testing, and demonstrating TI's audio power amplifier and related evaluation modules (EVMs). The platform saves the time, trouble, and expense of having circuit boards designed and fabricated to evaluate a specific IC. TI audio EVMs simply plug into the platform, which automatically provides power to the modules, interconnects them correctly, and connects them to a versatile array of standard audio input and output jacks and connectors. Easy-to-use configuration controls allow the platform and EVMs to quickly model many possible end-equipment configurations. There is nothing to build, nothing to solder, and nothing but the included speakers to "hook up."

The platform consists of a 6.5 inch by 7 inch piece of G-10 circuit board equipped with various signal input and output connectors, power connections, pin-sockets for TI audio EVMs, and switches and jumpers for signal routing and option selection (Figure 1-1). All the inputs are at one end, the outputs are at the other end, and the EVM sockets are in between for a straight signal path.

Figure 1-1. The TI Plug-N-Play Audio Amplifier Evaluation Platform

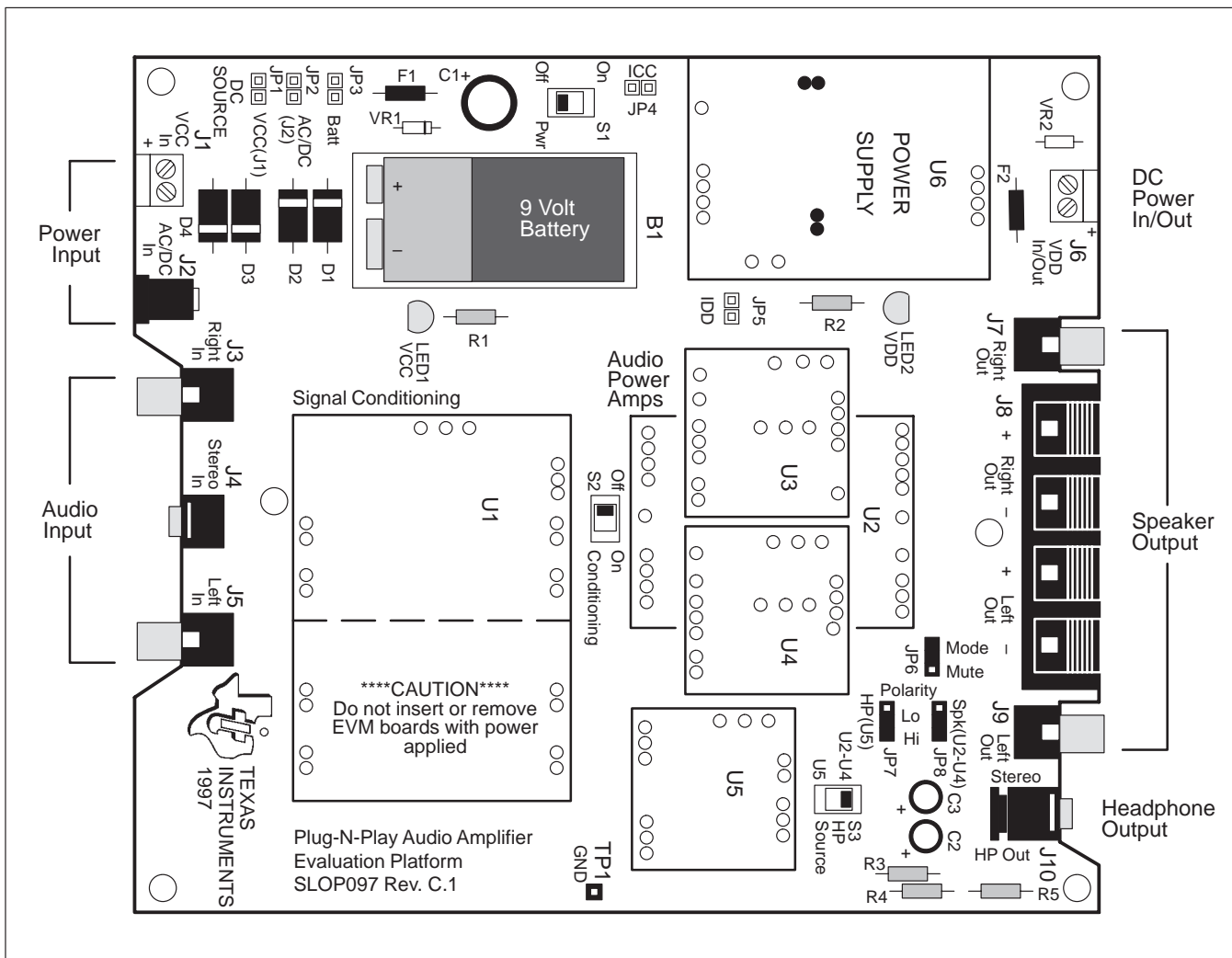

The audio EVM sockets are arranged into two stages on the platform (Figure 1–2): an input signal conditioning stage (socket U1) and an output power amplifier stage (sockets U2 through U5). The signal conditioning EVM can include such functions as volume and tone controls as well as the mixing of several sources, and can be bypassed with a switch on the platform. The output amplifier stage can be populated with a wide variety of EVMs, including both single-channel and stereo units, and is intended to drive speakers and headphones.

Figure 1–2. Functional Block Diagram

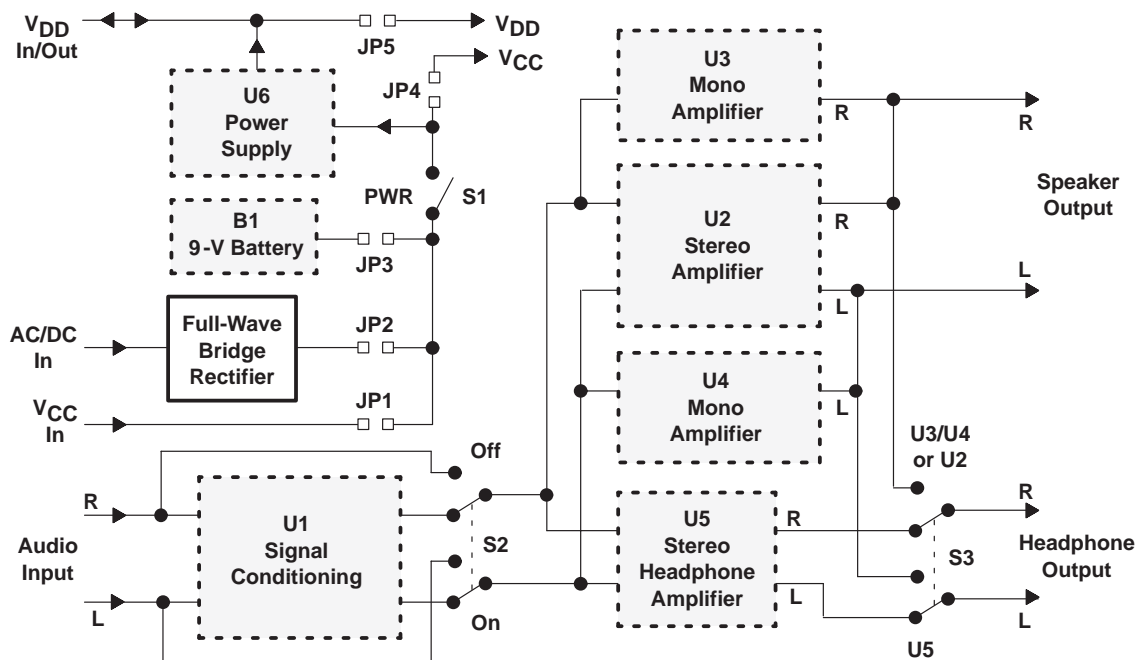

Signals are input through either a pair of RCA phono jacks (left and right channels) or a miniature stereo phone jack. These inputs are grounded when the jacks are not in use. Signal conditioning EVMs may have additional input connectors, as in the case of the Microphone Mixer EVM (SLOP107), which has a microphone input jack mounted on its circuit board.

The platform includes a pair of sockets for single-channel power amplifiers (U3 and U4) and a socket for a stereo power amplifier (U2). These sockets physically overlap each other such that either one or both mono amplifiers can be installed, **OR**, a single stereo amplifier can be installed — but not any combination of stereo with mono amplifiers. Output to speakers is through a pair of RCA phono jacks and compression connectors for use with stripped speaker wire.

Socket U5 is typically for a stereo headphone amplifier EVM. A miniature stereo headphone jack is capacitively coupled to either the headphone amplifier outputs or the power amplifier outputs as selected by a switch.

The platform V_{CC} supply can be provided by a wide variety of sources, including an on-board 9-V battery for low-power or short-duration projects and unregulated external AC or DC between 5 V and 15 V for other applications. For TI audio EVMs that require a regulated 3.3-V or 5-V V_{DD} supply, a voltage regulator EVM can be installed on the platform (U6), or external regulated V_{DD} power can be applied to a connector on the platform.



Quick Start

This chapter contains a quick-start list that explains how to configure the platform, connect power, connect the inputs and outputs, and power up the system.

Topic	Page
2.1 Precautions	2-2
2.2 Quick Start List	2-3

2.1 Precautions

Power Supply Input Polarity and Maximum Voltage

Always ensure that the polarity and voltage of the external power connected to V_{CC} power input connector J1, J2, and/or V_{DD} power input connector J6 are correct. Overvoltage or reverse-polarity power applied to these terminals can open on-board soldered-in fuses and cause other damage to the platform, installed evaluation modules, and/or the power source.

Inserting or Removing EVM Boards

Do not insert or remove EVM boards with power applied — damage to the EVM board, the platform, or both may result.

Figure 2–1. Quick Start Map

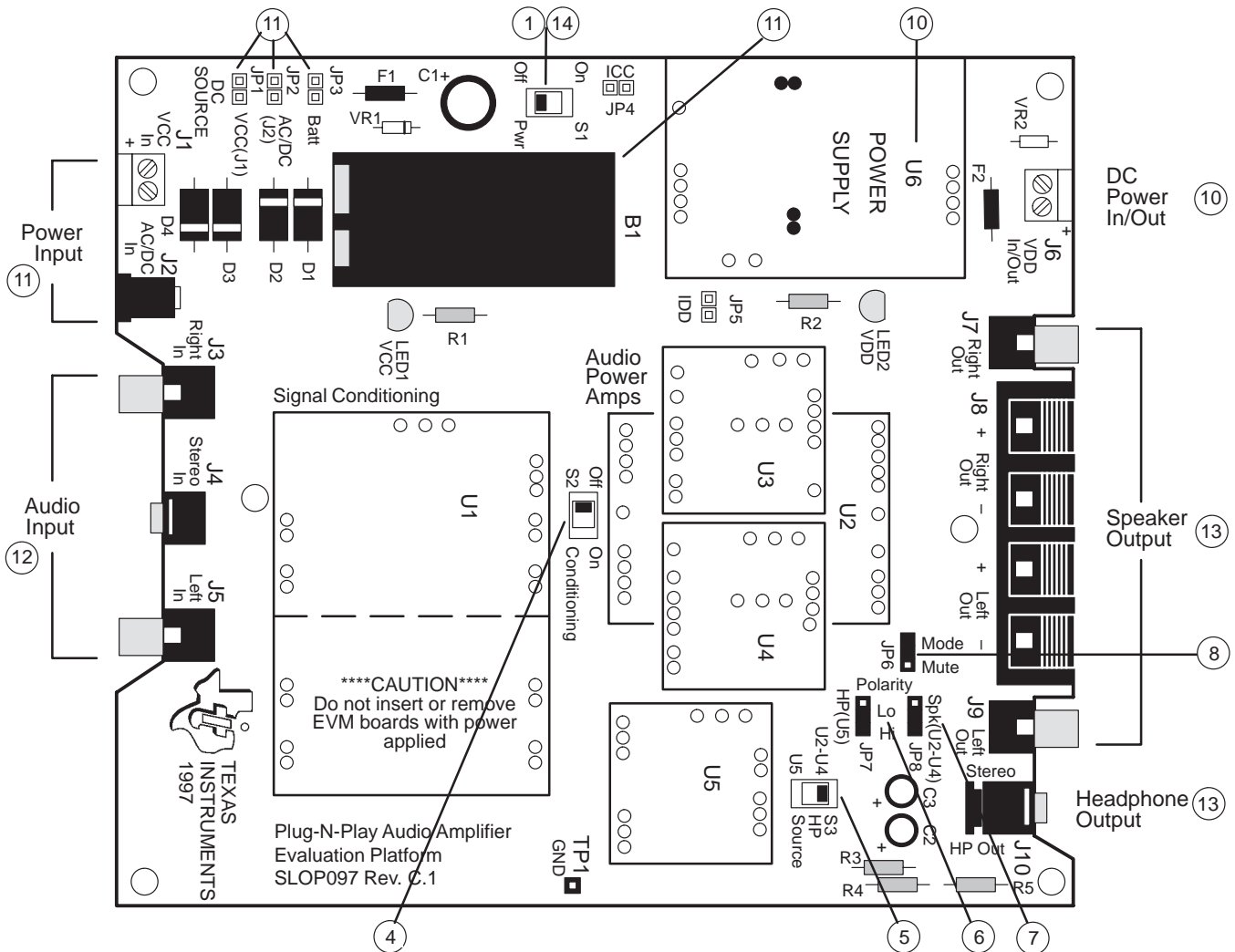

2.2 Quick Start List

The following steps can be followed to quickly prepare the TI Plug-N-Play Audio Amplifier Evaluation Platform and EVMs for use. Numbered callouts for selected steps are shown in Figure 2–1 and details for each step appear in Chapter 3.

□ Configure the platform

- 1) Ensure that all external power sources are set to **OFF** and that the platform power switch **S1** is set to **OFF**; set gain controls to minimum
- 2) Select the TI audio evaluation modules to be used
- 3) Install the modules on the platform in the appropriate sockets
- 4) Use switch **S2** to select or bypass the signal conditioning EVM (U1)
- 5) If the headphone jack (J10) output will be used, set source switch **S3** to **U5** or **U2–U4** according to which sockets have power amplifiers installed
- 6) Consult the User's Guide for the power amplifier installed in U5 (if any) and set control signal **Polarity** jumper **JP7** to either **Hi** or **Lo**
- 7) Consult the User's Guide for the power amplifiers installed in U2–U4 (if any) and set control signal **Polarity** jumper **JP8** to either **Hi** or **Lo**
- 8) Consult the User's Guide for the power amplifiers installed in U2–U4 (if any) and set jumper **JP6** to select either the **Mute** or **Mode** control input

□ Connect power supplies

- 9) Consult the User's Guides for the modules installed and select external power supplies that will provide a voltage appropriate for the modules installed (platform V_{CC} must be within the range of 5.5 V to 15 V, or 5.5 V to 12 V with a SLVP097 regulator module installed in U6, for example)
- 10) If any module installed on the platform requires a regulated V_{DD} of 3.3 V or 5 V for operation, install a SLVP097 regulator EVM (or equivalent) in U6 or connect an external regulated power supply adjusted to the correct voltage to screw terminals **J6**, taking care to observe marked polarity
- 11) Connect power to, and jumper **ONE** of the following V_{CC} power inputs:
 - a) Connect an external DC power supply to screw terminals **J1**, taking care to observe marked polarity, and jumper **JP1**
 - b) Plug a coaxial power connector (AC or DC) into **J2** and jumper **JP2**
 - c) Install a 9-V battery into **B1** and jumper **JP3**

□ Connect inputs and outputs

- 12) Connect the audio source to left and right RCA phono jacks **J3** and **J5** or stereo miniature phone jack **J4**
- 13) Connect 4- Ω – 8- Ω speakers to left and right RCA jacks **J7** and **J9** or to stripped wire connectors **J8**, or plug headphones into **J10**

□ Power up

- 14) Verify correct voltage input polarity and set external power supplies to **ON**, then set platform power switch **S1** to **ON**

LED1 should light indicating the presence of V_{CC} , LED2 should light indicating the presence of V_{DD} (if used), and the evaluation modules installed on the platform should begin operation.

- 15) Adjust signal source levels and EVM gain controls as needed



Details

This chapter provides details on the steps in the Quick-Start List and additional information on the TI Plug-N-Play Audio Amplifier Evaluation Platform.

Topic	Page
3.1 Precautions	3-2
3.2 Configuration	3-3
3.2.1 TI Audio EVMs	3-3
3.2.2 Installing and Removing EVM Boards	3-3
3.2.3 Signal Routing	3-4
3.2.4 Muting and Mode	3-5
3.3 Power	3-7
3.3.1 Platform Power Distribution	3-7
3.3.2 Platform Power Protection	3-7
3.3.3 Platform Power Inputs	3-8
3.4 Inputs and Outputs	3-11
3.4.1 Inputs	3-11
3.4.2 Outputs	3-12
3.5 Troubleshooting	3-13
3.6 Parts List	3-14
3.6 Platform EVM Socket Pinouts	3-15

3.1 Precautions

Power Supply Input Polarity and Maximum Voltage
 Always ensure that the polarity and voltage of the external power connected to V_{CC} power input connector J1, J2, and/or V_{DD} power input connector J6 are correct. Overvoltage or reverse-polarity power applied to these terminals can open on-board soldered-in fuses and cause other damage to the platform, installed evaluation modules, and/or the power source.

Inserting or Removing EVM Boards
 Do not insert or remove EVM boards with power applied — damage to the EVM board, the platform, or both may result.

Figure 3–1. The Platform

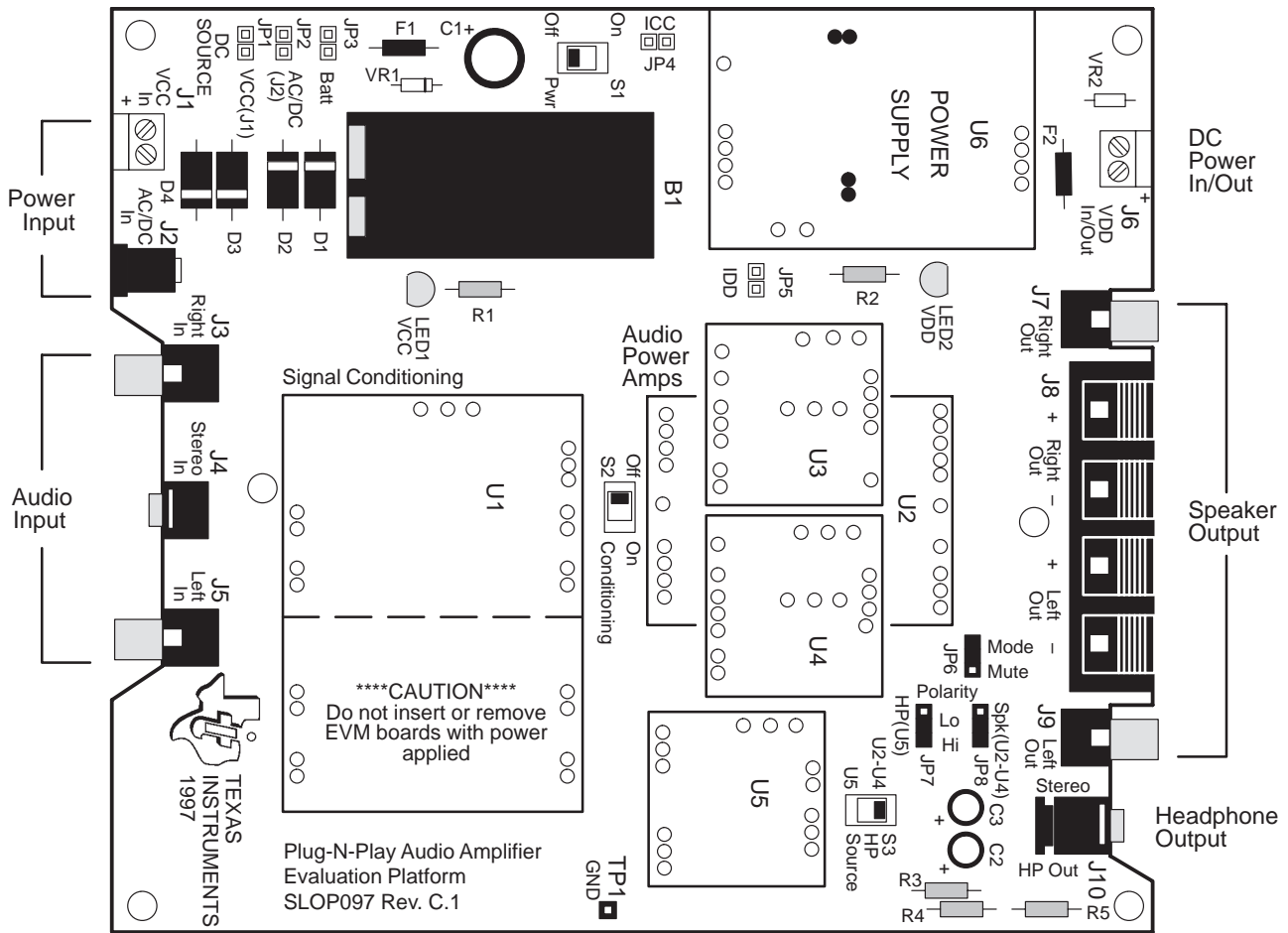

3.2 Configuration

Configuring the TI Plug-N-Play Audio Amplifier Evaluation Platform consists of selecting the appropriate TI audio EVMs for the application to be modeled, installing the modules on the platform, routing the signal, and setting the mode and mute options of the amplifier.

3.2.1 TI Audio EVMs

There are a wide variety of TI audio EVMs available for the platform. Contact any TI sales office to obtain additional audio EVMs or for information on any new audio EVMs that may have been released.

The platform is equipped with six evaluation module sockets (Figure 3–1):

- U1 Signal conditioning EVM socket
- U2 Stereo audio power amplifier EVM socket
- U3 Mono audio power amplifier EVM socket
- U4 Mono audio power amplifier EVM socket
- U5 Headphone audio power amplifier EVM socket
- U6 DC/DC converter/voltage regulator EVM socket

Various modules can be installed in combination, with the minimal configuration being simply a power output amplifier and a 9-V battery. Or, the platform can be populated with a full complement of modules. If a power output amplifier is to be installed, however, a choice must be made between either a stereo power output amplifier in socket U2, or one or two monaural power amplifier modules in sockets U3 and/or U4. A stereo headphone power amplifier can be installed in socket U5 whether any other power amplifiers are installed or not.

3.2.2 Installing and Removing EVM Boards

TI Plug-N-Play evaluation modules use single-in-line header pins installed on the underside of the module circuit board to plug into sockets on the platform. The EVM pins and the platform sockets are keyed such that only the correct type of EVM can be installed in a particular socket, and then only with the proper orientation.

Evaluation modules are easily removed from the platform by simply prying them up and lifting them out of their sockets. Care must be taken, however, to prevent bending the pins.

3.2.2.1 EVM Insertion

- 1) Remove all power from the evaluation platform
- 2) Locate the appropriate socket on the platform
- 3) Orient the module correctly

- 4) Carefully align the pins of the module with the socket pin receptacles
- 5) Gently press the module into place
- 6) Check to be sure that all pins are seated properly and that none are bent over

3.2.2.2 EVM Removal

- 1) Remove all power from the evaluation platform
- 2) Using an appropriate tool as a lever, gently pry up one side of the module a small amount
- 3) Change to the opposite side of the module and use the tool to pry that side up a small amount
- 4) Alternate between sides, prying the module up a little more each time to avoid bending the pins, until it comes loose from the socket
- 5) Lift the EVM off of the platform

3.2.3 Signal Routing

The audio signal from the input jacks can be applied to the signal conditioning socket (U1) if a signal conditioning EVM is installed, or socket U1 can be bypassed and the audio input signal applied directly to the inputs of the installed power amplifiers. Switch S2 selects signal conditioning or bypasses it (Figure 3–2).

Figure 3–2. Signal Routing Switches

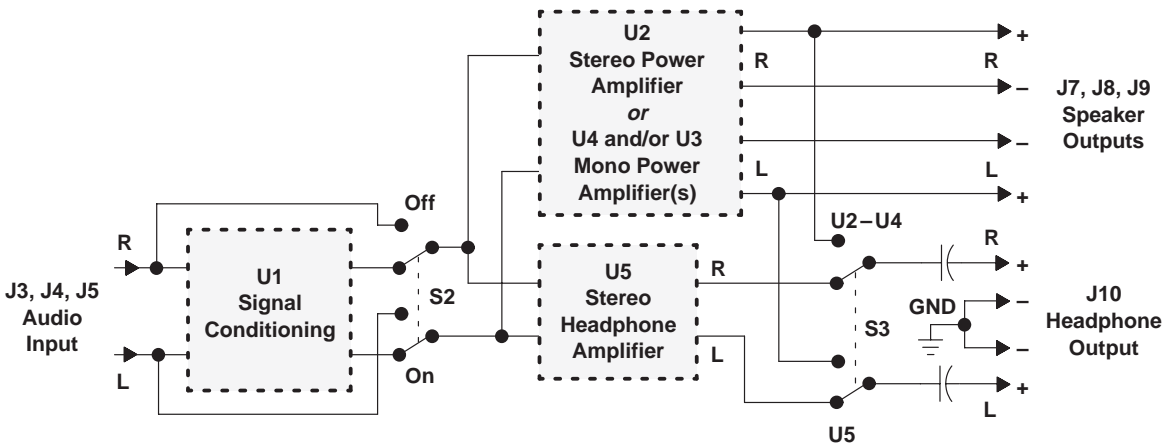

Switch S3 is the source select for the stereo headphone output jack, J10. The headphone jack is capacitively coupled and can output either the signal from the headphone amplifier in socket U5, or the output signal from the power amplifier(s) installed in socket U2 or U3 and/or U4, as determined by the setting of S3.

3.2.4 Muting and Mode

Many TI audio power amplifier EVMs have control inputs that mute the output and/or change the operating mode (from bridged to single-ended output, for example) in response to a signal applied to a control input. The typical application, as often found in notebook computers, portable audio products, and such, would have the internal speakers mute when headphones are plugged into the headphone jack, or have internal speakers mute when external speakers are connected.

In applications using separate speaker and headphone amplifiers, the one not being used can be shut down (muted) to conserve power. In applications that use a single power amplifier to run either the speakers or the headphones, or either the internal speakers or the external speakers, often the amplifier must switch its output mode to single-ended to be able to cope with the 3-wire headphone or external speaker connector that returns the signal to ground.

The TI Plug-N-Play Audio Amplifier Evaluation Platform has been designed to provide complete flexibility in selecting control signal polarity and functionality for amplifier muting and mode select.

3.2.4.1 Headphone Jack Control Signals

The platform headphone jack (J10) contains an internal switch that changes the state of a pair of control lines when a headphone plug is inserted. Each control line is pulled down by a 1-k Ω resistor to ground (R4 and R5). The switch in the headphone jack pulls one line or the other up to V_{DD} through a 240 Ω resistor (R3) depending on whether a headphone plug is inserted in J10 or not (Figure 3–3).

Figure 3–3. Mute/Mode Control

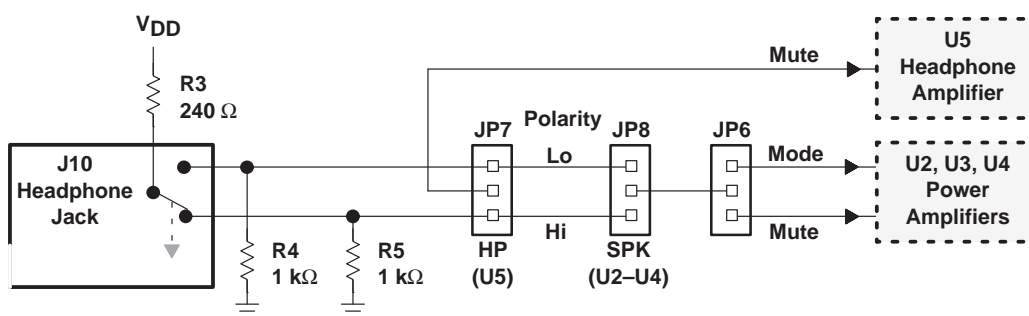

A 3-pin jumper header (JP7), functioning as a SPDT switch, selects the control signal polarity by connecting either the active-low or the active-high line from the headphone jack to the mute control input of the headphone amplifier socket, U5.

For the power amplifiers, sockets U2 – U4, a second three-pin jumper header (JP8) selects the control signal polarity by connecting either the active-low or the active-high line from the headphone jack to jumper JP6. JP6 connects the control signal from the headphone jack to either the mute or the mode control input of the power amplifier sockets.

3.2.4.2 Muting Polarity Select for Headphone Amplifier in U5 (JP7)

Jumper JP7 as indicated in the User’s Guide for the amplifier installed in U5, or:

- To mute EVMs that are being used as headphone amplifiers in U5 when the plug is *removed* from the headphone jack, jumper JP7 as follows:
 - If the EVM mutes on a low control signal, jumper **JP7 to Hi**
 - If the EVM mutes on a high control signal, jumper **JP7 to Lo**

3.2.4.3 Mute/Mode Select for Power Amplifiers in U3/U4 or U2 (JP6)

Jumper JP6 as indicated in the User’s Guide for the power amplifiers installed in U2 or in U3/U4, or:

- To change the mode (from BTL to SE, for example) of the power amplifiers installed in U3/U4 or U2 when a plug is *inserted* in the headphone jack, jumper **JP6 to Mode**
- To mute the power amplifiers installed in U3/U4 or U2 when a plug is *inserted* in the headphone jack, jumper **JP6 to Mute**

3.2.4.4 Mute/Mode Polarity Select for Power Amplifiers in U3/U4 or U2 (JP8)

Jumper JP8 as indicated in the User’s Guide for the power amplifiers installed in U2 or in U3/U4, or:

- To mute or change the mode of the power amplifiers installed in U3/U4 or U2 when a plug is *inserted* in the headphone jack, jumper JP8 as follows:
 - If the power amplifiers mute or change to the desired mode on a low control signal, jumper **JP8 to Lo**
 - If the power amplifiers mute or change to the desired mode on a high control signal, jumper **JP8 to Hi**

3.2.4.5 Mute/Mode Jumper Select Table

Table 3–1 shows the relationship between the control line polarity select jumpers (JP7 and JP8), the Mute/Mode select jumper (JP6), and the headphone plug for amplifier EVMs with *active-high* control inputs.

Table 3–1. Mute/Mode/Polarity Jumper Select Table

POWER AMPLIFIERS			HEADPHONE PLUG	HEADPHONE AMPLIFIER	
JP6	JP8	U2–U4		U5	JP7
Mute	Lo	Active	Present	Active	Lo
		Mute	Not present	Mute	
	Hi	Mute	Present	Mute	Hi
		Active	Not present	Active	
Mode	Lo	Mode A	Present		
		Mode B	Not present		
	Hi	Mode B	Present		
		Mode A	Not present		

3.3 Power

TI audio modules installed in the TI Plug-N-Play Audio Amplifier Evaluation Platform operate from either an unregulated V_{CC} supply or a regulated V_{DD} supply. The platform can be powered from an on-board battery or from any of several different external sources.

3.3.1 Platform Power Distribution

The platform is equipped with a number of connectors for power input, and a V_{CC} bus and a V_{DD} line for on-board power distribution. The V_{CC} bus uses jumper block JP1 **OR** JP2 **OR** JP3 to connect it to the desired power input connector. Only ONE of these jumpers should be installed at any one time.

On-board switch S1 applies V_{CC} power to the modules installed on the platform. Note that S1 also controls V_{DD} power only when V_{DD} is supplied by a power supply/voltage regulator module plugged into platform socket U6, and not when V_{DD} power is supplied from an external source at screw terminals J6. LED1 and LED2 indicate the presence of power on the V_{CC} bus and the V_{DD} line, respectively (Figure 3–4).

Figure 3–4. Platform Power Distribution

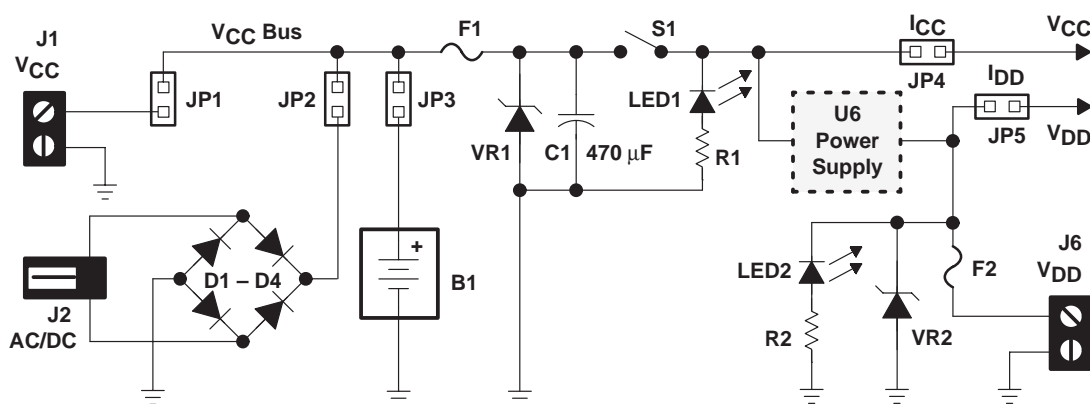

Jumper JP4 is in series with the V_{CC} bus and allows easy monitoring of module V_{CC} current consumption (I_{CC}). JP5 is in series with the V_{DD} line for I_{DD} measurement. Both current monitoring points are on the load side of the indicator LEDs, so their current consumption will not be part of the measurement.

3.3.2 Platform Power Protection

The platform V_{CC} bus and the V_{DD} line are protected against both excessive voltage levels and reverse power polarity by zener diodes and fuses connected to form crowbar circuits.

A zener diode is connected backwards between the V_{CC} bus and ground so that it is reverse-biased. If the input voltage exceeds the zener breakover voltage, the diode suddenly conducts heavily, forming a low-impedance path to ground. The resulting high current opens the fuse, removing the voltage.

If a reverse-polarity voltage is input, the zener, being forward biased, conducts immediately, and again the fuse opens. A similar circuit protects the V_{DD} line.

Note that the V_{CC} bus protection components are ahead of the platform power switch. And since there is no power switch for the V_{DD} line, both protection circuits will respond to reverse power polarity and overvoltage conditions at the moment they are applied to the platform power input connectors. Power polarity and voltage levels must be set and verified before external power is applied to the platform.

Correct polarity and maximum voltage levels should always be strictly observed because not only is the operation of the crowbar circuit always destructive to some degree (at a minimum, the opened fuse must be unsoldered and replaced), there is always the chance for damage to the platform, the installed modules, and/or the external power source before the fuse opens.

Damage to the protection circuit and/or the platform (beyond an open fuse) can occur if the external power supply is unable to provide at least 3 amps of current to ensure the fuse opens quickly. Lower currents can cause failure of the zener diode and possibly damage to the platform PCB traces from overheating.

3.3.3 Platform Power Inputs

The evaluation modules installed on the platform can be powered by a wide variety of V_{CC} sources including:

- On-board 9-V battery
- Unregulated external DC at screw terminals J1
- Unregulated external AC or DC at coaxial power connector J2

And for those TI audio EVMs that require a regulated V_{DD} supply:

- Regulated DC from on-board power supply/regulator (socket U6)
- Regulated external DC at screw terminals J6

Selecting the appropriate power source may depend on the requirements of the various modules in the audio system assembled on the platform, or simply on what is available (as long as platform and EVM requirements are met).

3.3.3.1 Power Requirements

Platform V_{CC} voltage limits are governed by the lowest level that will operate all of the installed modules and the highest level that the modules (or the platform overvoltage protection circuit) will tolerate. In general, however, the V_{CC} input voltage should be in the range of:

- Approximately 3.3 V to a maximum of 15 V
- Approximately 5.5 V to a maximum of 12 V if a SLVP097 power supply/voltage regulator module is installed in U6

Some TI audio EVMs require a regulated V_{DD} supply (3.3 V or 5 V typical) for operation. This can be provided by a power supply/voltage regulator EVM installed in platform socket U6 (runs off of the platform V_{CC} bus) or by an external regulated supply. If an external V_{DD} source is used, depending on the EVM requirements, V_{DD} should be:

- 3.3 V or 5 V, and must not exceed 6 V

3.3.3.2 On-Board 9-V Battery

Many low-power portable and battery-powered audio systems can be modeled on the platform with TI audio EVMs. It may make sense, then, to power these system models on the platform using an on-board battery. The platform is equipped with a snap-in battery holder for a common 9-V battery and jumper JP3 connects the battery to the V_{CC} bus, which routes the battery voltage to the various EVM sockets.

Since the V_{CC} bus also supplies the on-board power supply/voltage regulator socket, the battery voltage can be input voltage for a power supply/regulator EVM plugged into U6. The regulator EVM then supplies regulated voltage to the V_{DD} line for use by those EVMs that require regulated V_{DD} power.

For high-power audio system evaluation and demonstration, one of the other platform power supply options should be selected.

3.3.3.3 Unregulated External DC at Screw Terminals J1

Unregulated DC voltage from a bench-type supply or any other source of DC power within the required voltage range can be connected to screw terminals J1 for V_{CC} power. Jumper JP1 connects J1 to the V_{CC} bus for distribution.

Voltage applied to screw terminals J1 *MUST* be of the correct polarity and *MUST NOT* exceed 15 V or the power protection circuit on the V_{CC} bus will trip.

3.3.3.4 Unregulated External AC or DC at Coaxial Power Connector J2

The coaxial power jack, J2, matches a large number of the typical wall-cube-type power transformers/power supplies. Although the jack is of a standard size (5.5 mm O.D. \times 2.1 mm I.D.), there does not seem to be any standard for voltage polarity or power type (AC or DC) among wall-cubes and other power sources using a coaxial power plug. To ensure the widest possibility compatibility, the platform is equipped with a full-wave bridge rectifier between the coaxial connector and the V_{CC} bus to allow DC voltage of either polarity, or AC voltage to be input through J2. Jumper JP2 connects J2 to the V_{CC} bus for distribution.

The bridge rectifier eliminates the need to determine the plug polarity for input voltage at J2 and rectifies AC voltage applied to J2 into DC before it is connected to the V_{CC} bus. An on-board filter capacitor on the bus smooths the rectified AC.

With DC voltage applied to J2, the bridge rectifier introduces a voltage drop of approximately 1.4 V (two diode forward-drops). This drop must be taken into account if the DC voltage applied to J2 is at or near the minimum required for operating a module installed on the platform, and the external voltage supply adjusted accordingly.

With an AC voltage applied to J2, V_{CC} bus voltage depends on several factors, including the load on the bus. As a general rule for typical AC voltage inputs, however, V_{CC} bus voltage will be approximately the peak value of the applied AC voltage.

The bridge rectifier also causes the platform ground bus to be approximately 0.7 V above the ground of other equipment that might be operated by the same external power supply. Platform V_{CC} and EVM voltage measurements should be referenced to the platform ground bus (test point TP1, for example) and not the external power supply ground when V_{CC} voltage is supplied from J2.

V_{CC} voltage *MUST NOT* exceed 15 V or the overvoltage protection circuit on the V_{CC} bus will trip.

3.3.3.5 Regulated DC From On-Board Regulator (Socket U6)

A power supply/voltage regulator EVM can be installed in platform socket U6 to provide a regulated V_{DD} voltage (3.3 V or 5 V typical) for audio evaluation modules installed on the platform that require it. The regulator EVM uses power from the V_{CC} bus as an input and provides the appropriate regulated voltage to the platform V_{DD} line.

V_{DD} voltage also appears at screw terminals J6, where it can be used as a source of regulated power for off-board use, subject to the maximum current capabilities of the regulator module installed in U6 and the platform V_{CC} supply.

Do not allow the V_{CC} voltage to exceed the maximum specified for the installed power supply/voltage regulator EVM.

3.3.3.6 Regulated External DC at Screw Terminals J6

Regulated voltage (3.3 V or 5 V typical — 6 V maximum) from an external source can be connected to screw terminals J6 to supply the platform V_{DD} line for audio evaluation modules installed on the platform that require a regulated V_{DD} supply.

Voltage applied to screw terminals J6 *MUST* be of the correct polarity and *MUST NOT* exceed 6.1 V or the power protection circuit on the V_{DD} line will trip.

3.4 Inputs and Outputs

TI Plug-N-Play Audio Amplifier Evaluation Platform is equipped with several standard connectors for audio inputs and outputs.

3.4.1 Inputs

In most cases, audio signals enter the platform through either a pair of RCA phono jacks (J3 and J5) or a miniature (1/8") stereo phone jack (J4). Certain EVMs, however, may have additional signal input connectors mounted on the module circuit board.

The platform audio signal input jacks (J3, J4, and J5) are of the closed-circuit type and are interconnected such that the stereo phone jack is in series with the RCA phono jacks, and the signal lines are grounded when no plugs are inserted (Figure 3–5).

Figure 3–5. Platform Audio Input Jacks

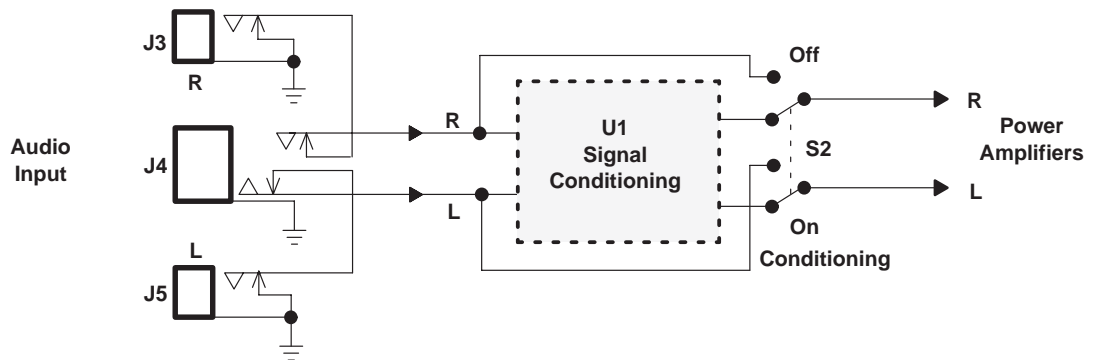

The internal switches in the RCA phono jacks (J3 and J5) connect the signal lines to ground when a plug is not inserted. The internal switches in the stereo phone jack (J4) connect the module signal inputs to the RCA phono jacks when a plug is not inserted in the stereo phone jack. These connectors operate as follows:

- With no plugs inserted, the signal lines to the inputs of the signal conditioning socket, U1*, are shorted to ground.
- With plugs inserted into the RCA phono jacks (J3 and J5) only, the signal from the phono plugs is routed through the stereo phone jack internal switches and then on to socket U1*.
- With a plug inserted into the stereo phone jack (J4), the RCA phono jacks are disconnected from the input and the signal from the phone plug is applied to socket U1*.

* or to power amplifier sockets if S2 is set to **OFF** to bypass conditioning

3.4.2 Outputs

Amplified audio signals leave the platform through left and right RCA phono jacks (J7 and J9), left and right pairs of compression connectors for stripped speaker wires (J8), and a capacitively-coupled miniature (1/8") stereo phone jack (J10) for headphones (Figure 3–6).

Figure 3–6. Platform Audio Output Jacks and Connectors

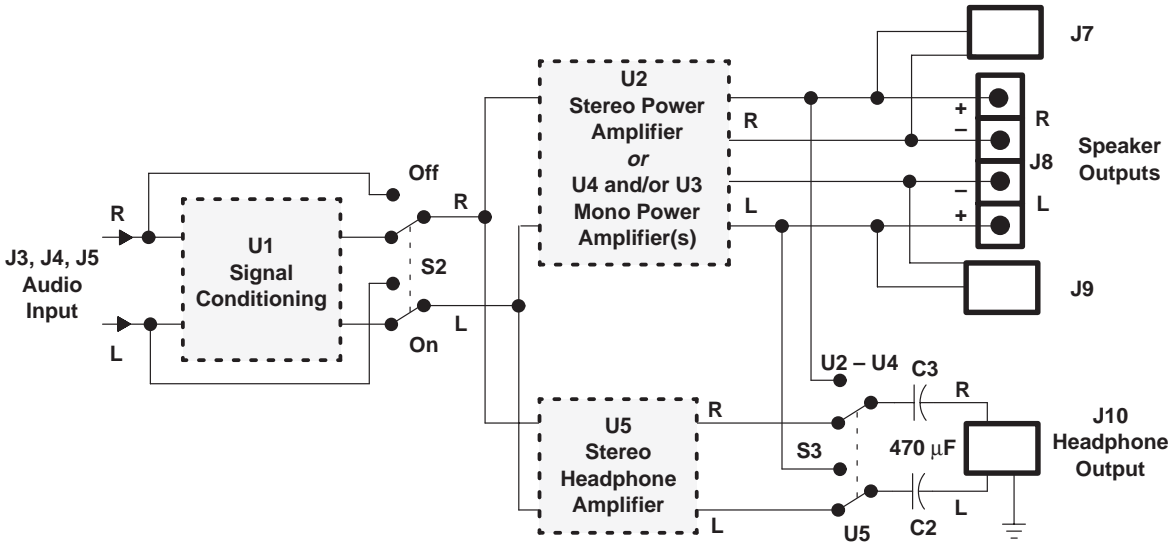

3.4.2.1 Power Amplifier Outputs/Jacks

The audio output lines from the power amplifiers are separate all the way to the edge of the platform (output jacks J7, J8, and J9) — the Out – lines from the power amplifier sockets are not tied to each other or to platform ground. This allows certain power amplifier EVMs to operate in various output drive modes, including some highly-efficient bridged configurations. To reduce possible emissions, limit the length of speaker wiring to 1 meter or less.

3.4.2.2 Headphone Amplifier Output/Jack

The headphone jack (J10) is a stereo miniature phone jack that is capacitively coupled (via 470 µF electrolytics) to S3. Source select switch S3 connects the headphone jack to the output lines of either the headphone amplifier socket U5, or to the output lines of the power amplifier sockets (U2, U3, and U4).

Some of the TI power amplifier EVMs that can be installed in sockets U2, U3, or U4 normally operate in the single-ended output mode, and some have the ability to switch from a bridged output mode to single-ended in response to a mode control signal. S3 should not be set to the power amplifier position unless power amplifiers that can operate in the single-ended mode are installed.

When S3 is set to the power amplifier position (**U2 – U4**), the headphone jack is connected to the power amplifier Out + output lines. When a headphone plug is inserted into the jack, these output lines are returned to the common platform ground inside J10, requiring single-ended power amplifier outputs. For power amplifier modules that have selectable output modes, a switch inside the headphone jack sends a control signal to the power amplifier sockets that can select the single-ended output mode when a headphone plug is inserted.

3.5 Troubleshooting

This section covers some of the possible difficulties that might be encountered with platform operation.

- The platform is connected to an external power source for V_{CC} and a voltage regulator EVM is installed in U6. Neither LED is lit and the EVM modules are not receiving power.
 - Check that platform power switch S1 is set on **ON**
 - Check that JP1 or JP2 or JP3 is jumpered and corresponds to the power source
 - Check fuse F1; replace it if it is found to be open
 - Check platform power switch S1; replace it if it is found to be faulty
- The platform is connected to an external power source for V_{CC} and a voltage regulator EVM is installed in U6. Only LED1 (V_{CC}) is lit. There is no V_{DD} at JP5 and the installed EVMs do not function properly.
 - Check that the voltage regulator EVM is fully seated in socket U6 and that none of the pins are bent over
 - Substitute a known-good voltage regulator EVM for the module in U6
- The platform is connected to an external power source for V_{DD} at J6. LED2 (V_{DD}) is dark and V_{DD} is not reaching the EVMs.
 - Check for correct V_{DD} input supply voltage
 - Check fuse F2; replace it if it is found to be open
- Power amplifier EVMs installed in U2, U3, and/or U4 are powered correctly but produce no sound.
 - Consult the User's Guide for the installed power amplifier and determine 1) if the EVM is mute active-high or mute active-low, and 2) which pin on the module is the mute control input. Measure the voltage at the mute control input pin of the installed module with *no* plug inserted in headphone jack J10. If the EVM is mute active-high and the mute pin of the EVM measures V_{DD} , the EVM is being held in the mute mode. Jumper the *other* pin on JP8 to reverse the mute control line polarity.
- The power amplifier EVM installed in U5 is powered correctly, but there is no sound from headphones when plugged into headphone jack J10.
 - Check that the headphone jack source select switch (S3) is set to the **U5** position
 - Consult the User's Guide for the installed power amplifier and determine 1) if the EVM is mute active-high or mute active-low, and 2) which pin on the module is the mute control input. Measure the voltage at the mute control input pin of the installed module *with* the headphone plug inserted in jack J10. If the EVM is mute active-high and the mute pin of the EVM measures V_{DD} , the EVM is being held in the mute mode. Jumper the *other* pin on JP7 to reverse the mute control line polarity.

3.6 Parts List

Table 3–2. Plug-N-Play Audio Amplifier Evaluation Platform Parts List

Ref	Description	Source	Part No.
B1	Battery, 9-V		
C1	Capacitor, Aluminum, 470 μ F, 25 V	Digi-Key	P5704-ND
C2	Capacitor, Aluminum, 470 μ F, 16 V	Digi-Key	P6230-ND
C3	Capacitor, Aluminum, 470 μ F, 16 V	Digi-Key	P6230-ND
D1	Diode, Rectifier, 3 A, 50 V	Mouser	583-1N5400
D2	Diode, Rectifier, 3 A, 50 V	Mouser	583-1N5400
D3	Diode, Rectifier, 3 A, 50 V	Mouser	583-1N5400
D4	Diode, Rectifier, 3 A, 50 V	Mouser	583-1N5400
F1	Fuse, Pico II, 3 A, 125 V, Fast-acting	Littelfuse	251-003
F2	Fuse, Pico II, 3 A, 125 V, Fast-acting	Littelfuse	251-003
J1	Connector, 2-pin, screw connector, 0.2" centers	Mouser	506-2MV02
J2	Jack, Power, 2.1 mm, PC mount	Mouser	163-5004
J3	Phone Jack, switched, PC mount	Mouser	16PJ396
J4	Phone Jack, Stereo, 1/8"	Mouser	161-3504
J5	Phone Jack, switched, PC mount	Mouser	16PJ396
J6	Connector, 2-pin, screw connector, 0.2" centers	Mouser	506-2MV02
J7	Phone Jack, switched, PC mount	Mouser	16PJ396
J8	Connector, 4-pin	Radio Shack	274-622A
J9	Phone Jack, switched, PC mount	Mouser	16PJ396
J10	Phone Jack, 1/8" with SPDT switch	Mouser	161-3503
JP1 – JP8	Header, 2-pin, 100-mil centers, 0.23" top, 0.22" bottom	Digi-Key	S1022–36–ND
LED1	LED, T1-3/4, Org, 25-mA		
LED2	LED, T1-3/4, Red, 25-mA		
R1	Resistor, CF, 430 Ohm, 1/2 W, 5%		
R2	Resistor, CF, 150 Ohm, 1/4 W, 5%		
R3	Resistor, CF, 240 Ohm, 1/4 W, 5%		
R4	Resistor, CF, 1.0 K Ohm, 1/4 W, 5%		
R5	Resistor, CF, 1.0 K Ohm, 1/4 W, 5%		
S1	Switch, DPDT, 0.2-A, 30-V, pc mount	Digi-Key	EG1908-ND
S2	Switch, DPDT, 0.2-A, 30-V, pc mount	Digi-Key	EG1907-ND
S3	Switch, DPDT, 0.2-A, 30-V, pc mount	Digi-Key	EG1907-ND
VR1	Diode, Zener, 15 V, 1 W, 5%, DO-41	Diodes, Inc.	1N4744A
VR2	Diode, Zener, 6.2 V, 1 W, 5%, DO-41	Diodes, Inc.	1N4735A
XB1	Battery Holder, 9-V, pc mount	Keystone	1294K
PCB	Printed Circuit Board, 2-layer		SLOP097
	Socket Pins, 0.022"–0.032" (Qty: 106) Mil-Max #0295–0–	Digi-Key	ED5008-ND
	Standoff, Nylon, 0.375"/6–32 (Qty: 6)	Digi-Key	8441BK-ND
	Screw, 0.25"/6–32 (Qty: 6)	Digi-Key	
	SHUNT, black, closed top (Qty: 3)	Mouser	151-8010
	SHUNT, red, open top (Qty: 3)	Mouser	151-8003

3.7 Platform EVM Socket Pinouts

Figure 3–7. Signal Conditioning Socket U1 Pinout

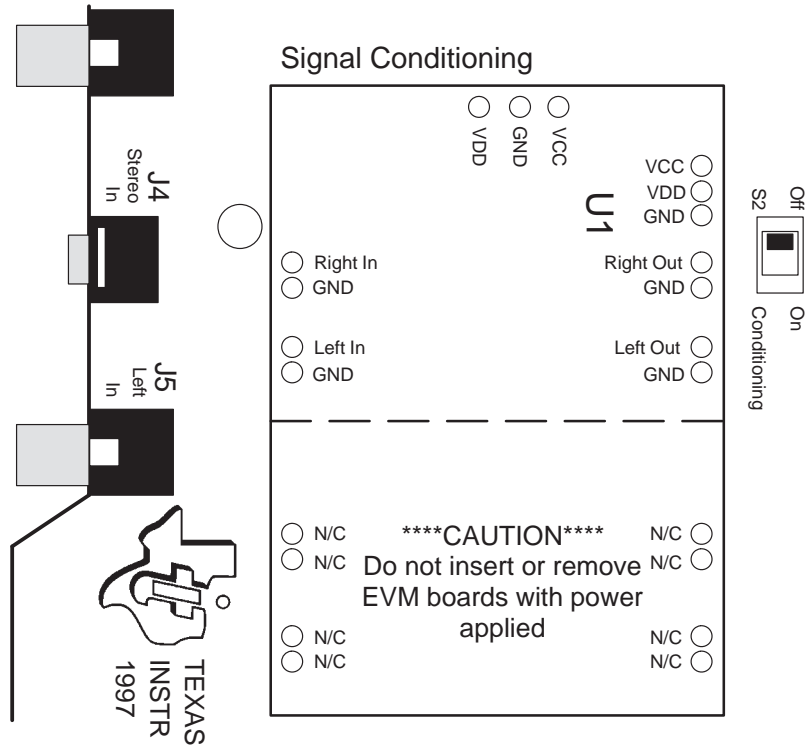

Figure 3–8. Power Amplifier Socket U2 Pinout

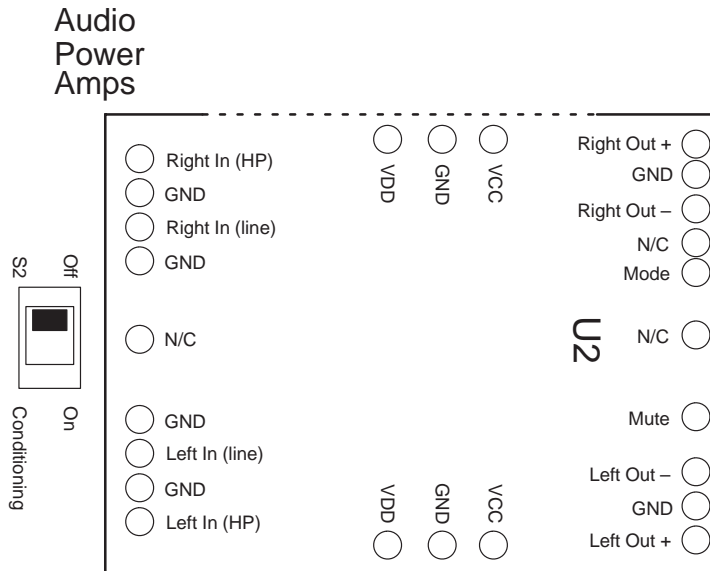

Figure 3–9. Power Amplifier Socket U3/U4 Pinout

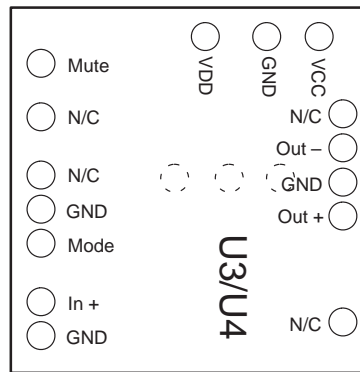

Figure 3–10. Headphone Amplifier Socket U5 Pinout

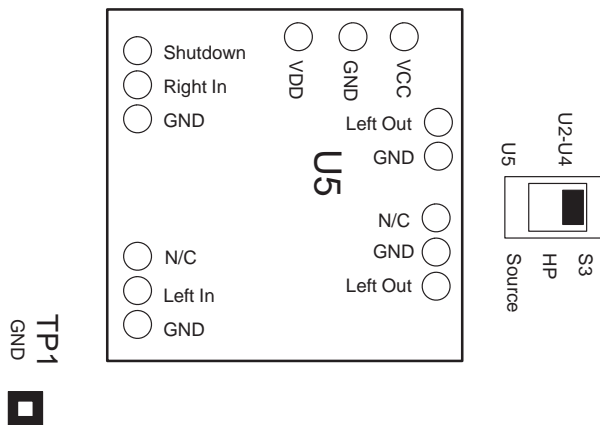

Figure 3–11. Power Supply/Regulator Socket U6 Pinout

